

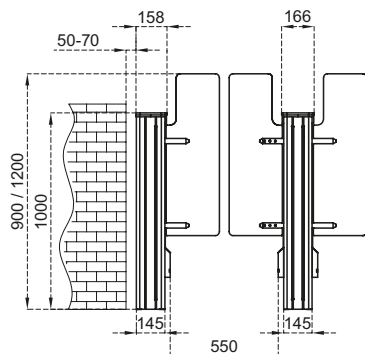

### Dimensions (mm)

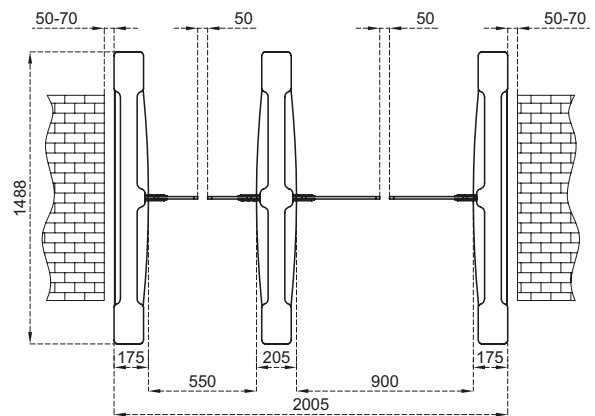

+ ... n ... +

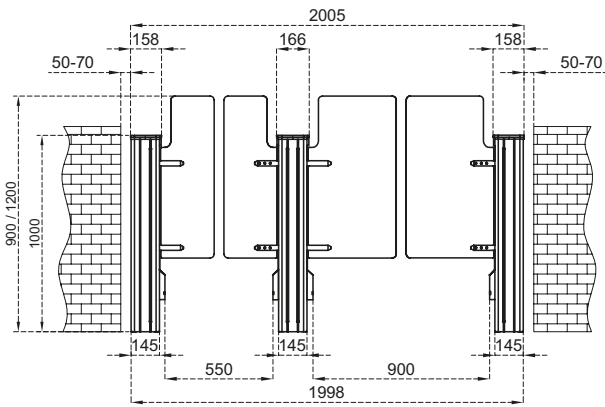
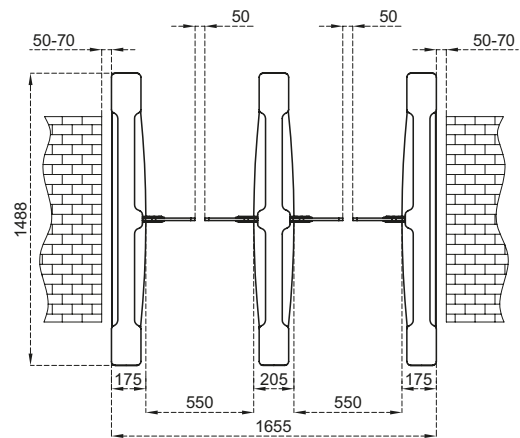
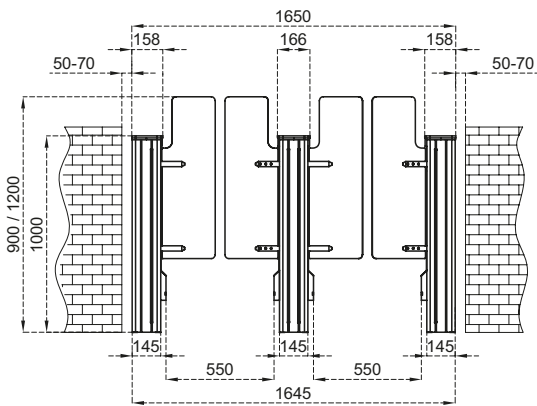
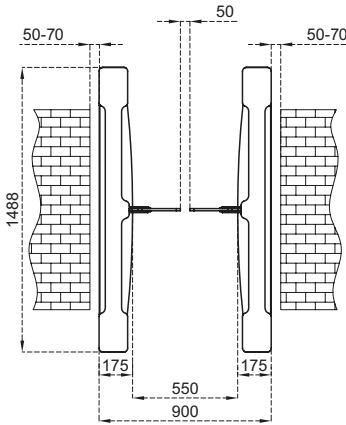
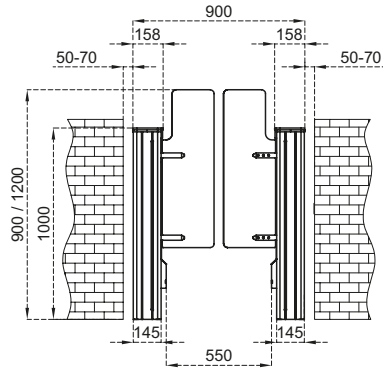